

TECHNICAL DATA SHEET

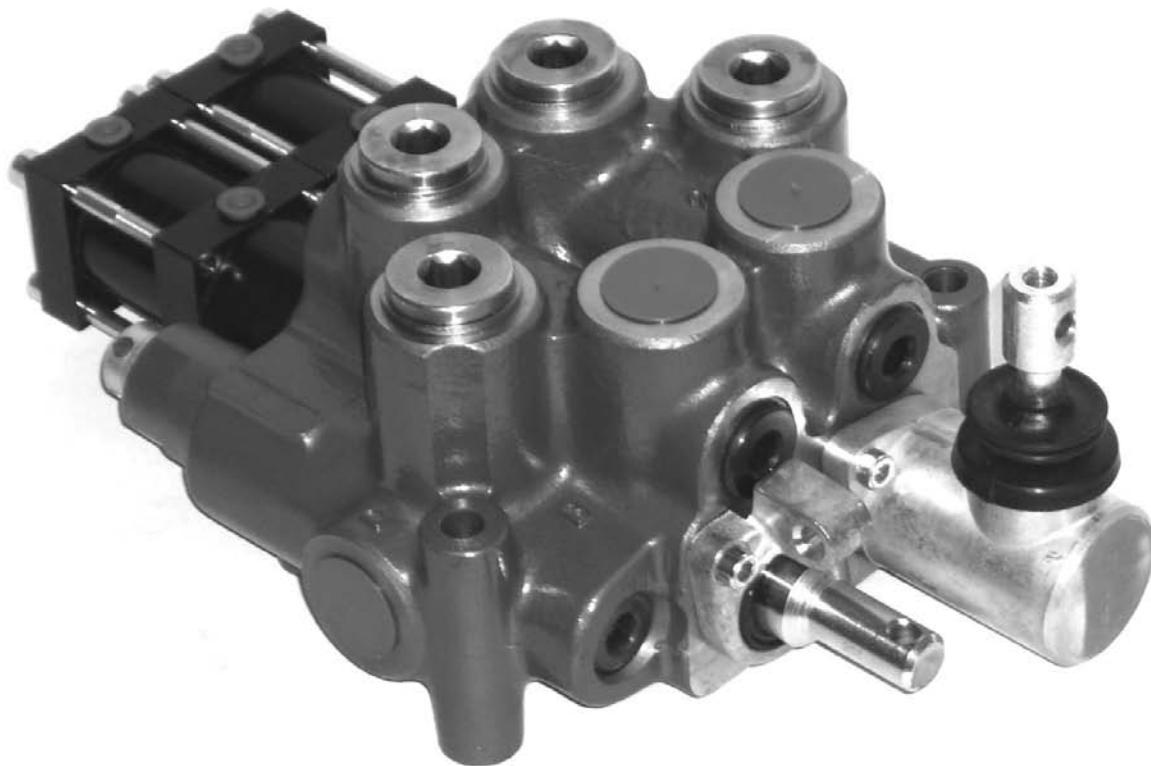

TRUCK AND TRAILER VALVES

The 204 valve has been designed in response to the changing needs of the modern truck market.

These valves provide another option for truck and trailer applications where dual tipping or compact size is required, in conjunction with high flow rates.

When used with a dual hoist control (CK108) these valves provide a compact solution to a common problem.

SUITS:

Truck and trailer applications

204 SERIES

TRUCK & TRAILER VALVES

PRODUCT FEATURES

- **COMPACT SIZE**
For minimum problems in fitting and mounting.
- **MONOBLOCK CONSTRUCTION**
For maximum integrity
- **AIR OPERATED**
For ease of engagement
- **HIGH FLOW RATES**
For use with systems requiring up to 140 l/min

DEALER:

TECHNICAL DATA SHEET

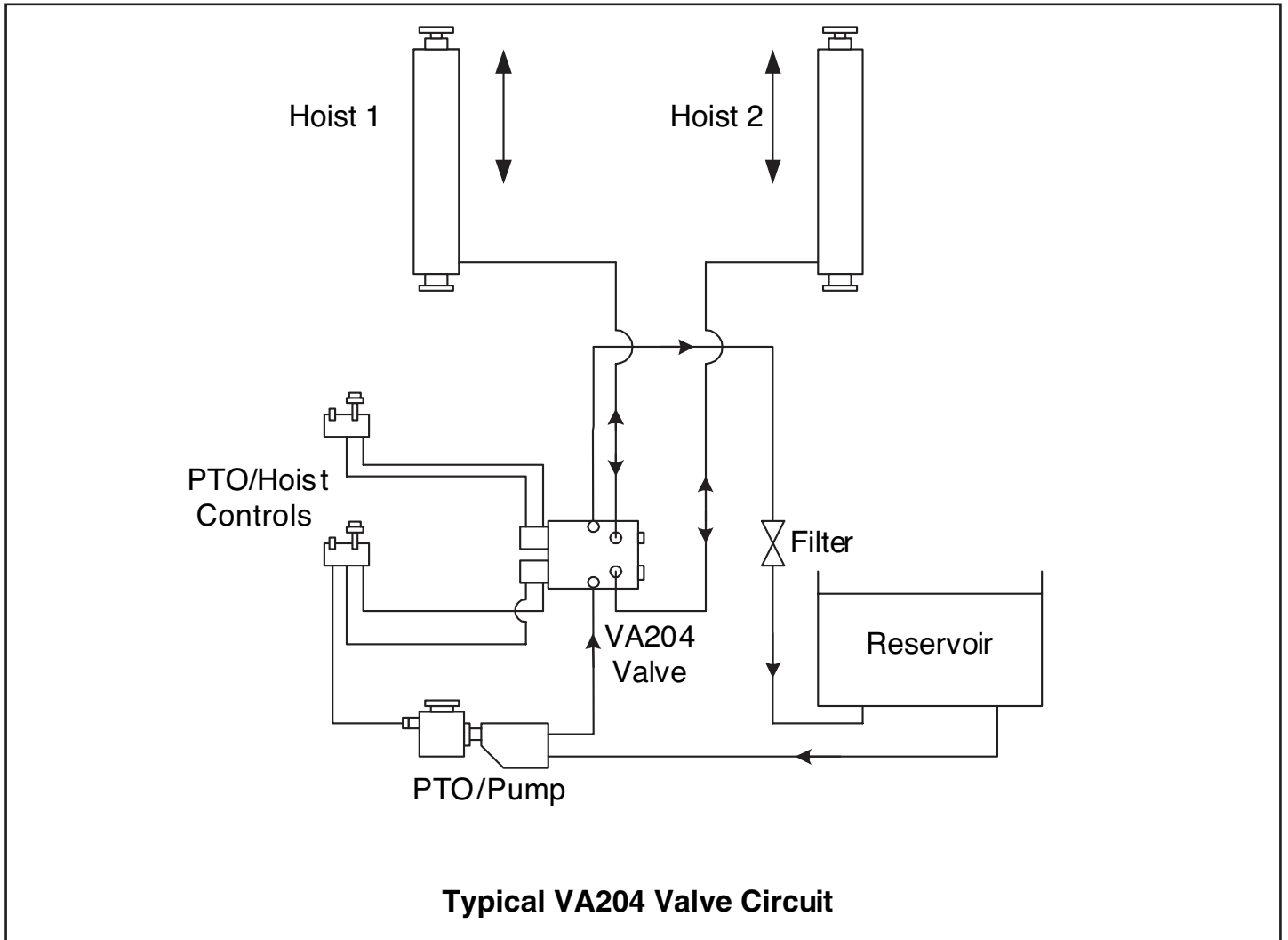

Technical Specification

Part Number	VA 204A140B
Number of spools	2
Spool function	Single acting
Flow capacity	140 l/min
Port sizes 'P' & 'B'	3/4 inch BSPP
Port Size 'T'	1 inch BSPP
Dampened on lower	Yes

