

# TECHNICAL DATA SHEET



## LOW RATIO HEAVY DUTY SIDE MOUNTED HOTSHIFT POWER TAKE-OFF

The 36 series is a constant mesh PTO designed to suit 10 bolt transmission openings on the MD and HD series Allison automatic transmissions.

This PTO has a high torque rating which is well suited to heavy duty applications.

### SUITS:

Allison MD 3050P, 3060P, 3070PT, 3550P, 3560P, HD 4060P, 4560P.

## 36 SERIES POWER TAKE-OFF

### PRODUCT FEATURES

- **RATIO OF 0.927 OR 1.323 (TRANSMISSION DEPENDANT)**  
Giving good output values for all applications
- **INTERNAL CLUTCH SYSTEM**  
Ensuring no gear clash when engaging  
Ability to engage when moving
- **VITON SEALS AND 'O' RINGS**  
Ensuring compatibility with high temperature conditions
- **'ONE GASKET, ONE HOSE' FITMENT**  
Simple to install, resulting in lower installation costs.
- **LOW PROFILE**  
Providing easier installation on narrow chassis.

DEALER:

# TECHNICAL DATA SHEET

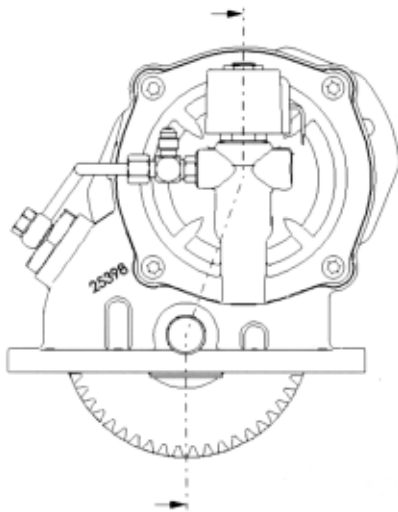
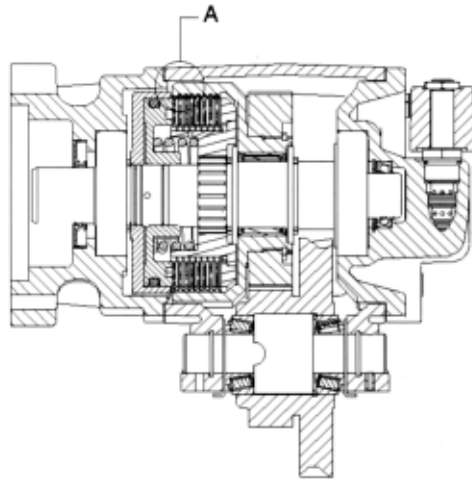

## PTO DESIGNATION CODES 36 series PTO

PA 36 JB L11 F 13 C

### Identifier

PA = PTO Side mount

### PTO series

36

### Gear Type

JB

### Build

R = Right side of transmission

L = Left side of transmission

1 = Selector to top / Bias to bottom

2 = Selector to bottom / Bias to top

1 = Centre to front } Position of gear  
in transmission

### Engagement Type

F = Electric / Hydraulic 12V

G = Electric / Hydraulic 24V

H = Electric Solenoid control 12V or 24V (Voltage identified on coil)

J = Hydraulic

### Output Type

08 = 8T Powauto Hydraulic Spline

09 = 35 x 60 Flange

11 = 1410 Flange

13 = 13T SAE B

Other outputs on request.

### Manufacturers Code

C = With mounting kit & PTO control kit

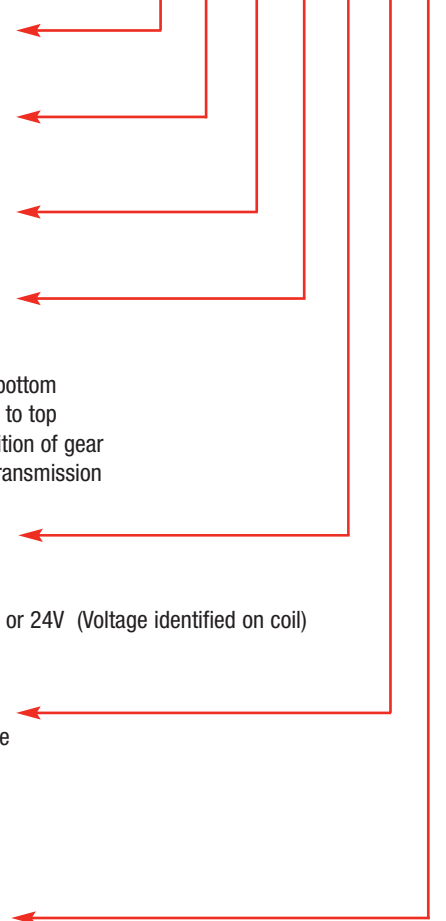

For full details refer to owners' manual.

## Technical Specifications

### Rating for intermittent duty

Torque (Nm /ft lb)	441/326
Power @ 500 rpm output shaft (kW / hp)	23/31
Power @ 1000 rpm output shaft (kW / hp)	46/62
Output Shaft Rotation	Same as engine
Approximate Bare Mass (kg / lb)	19/42
Mounting Kit	Included

For full details refer to your Powauto distributor

### Spare parts:

Seal Kit:

Bearing Kit:

Mounting Gasket Kit:

Seals & gaskets (minor overhaul)

Bearings/seals and gaskets (major overhaul)

Gears and shafts sold separately

SK063

BK063

GK023