

# TECHNICAL DATA SHEET

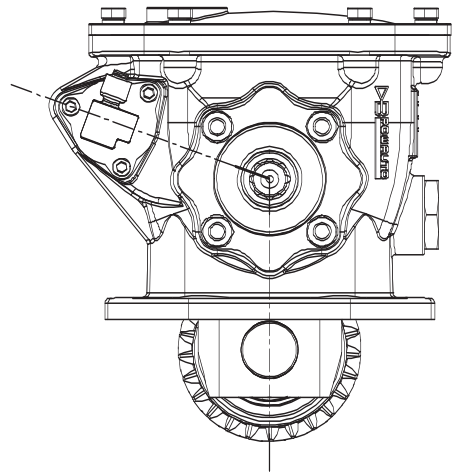
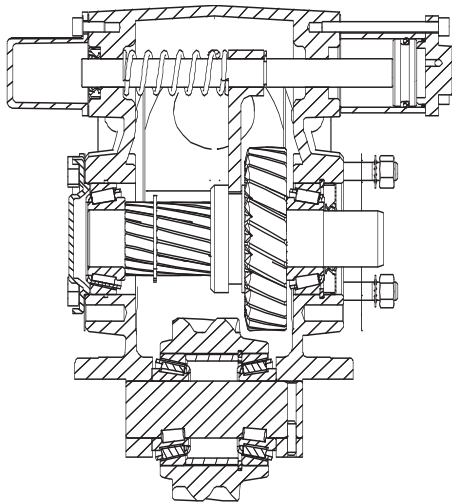

## PTO DESIGNATION CODES

### 404 series PTO

PA 404 SC L24 A 13 \*

#### Identifier

PA = PTO Side mount

#### PTO series

404

#### Gear Type

SC

#### Build

L = Left side of trans  
2 = Selector to bottom  
4 = Rear to Centre - Position of gear in transmission

#### Engagement Type

A = Air  
E = Electric/Air 24V

#### Output Type

08 = 8T Powauto Hydraulic Spline  
09 = 14T 12/24 30° Spline + 35 x 60 Flange  
10 = 14T 12/24 30° Spline + 1310 Series Flange  
11 = 14T 12/24 30° Spline + 1410 Series Flange  
12 = 14T 12/24 30° Spline + DIN 10 Flange  
13 = 13T SAE B Hydraulic Spline + Mount  
14 = 13T SAE B Hydraulic Spline  
23 = DIN 5462 Pump Mount

#### Manufacturers Code

A = With pressure switch  
B, C etc. (internal use only, if required)

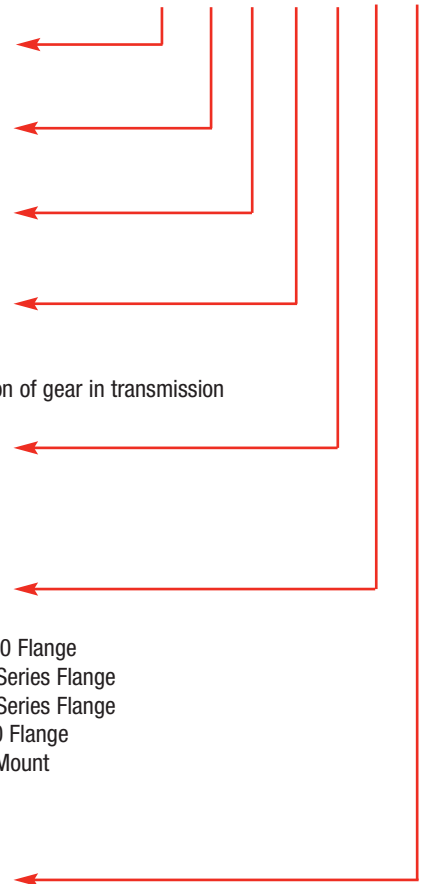

For full details refer to owner's manual

## Technical Specifications

### Rating for intermittent Service

Torque (Nm / lb ft)	380/280
Power @ 500 rpm (kW / hp)	19.8/26.5
Power @ 1000 rpm (kW / hp)	39.6/53.0
Output Shaft Rotation	Opposite
Approximate Bare Mass (kg / lb)	9.0/20
Mounting Kit	MK1118B

**For full details refer to Powauto or consult your applications book.**

#### Spare parts:

Seal Kit:

Bearing Kit:

Mounting Gasket Kit:

Seals & gaskets (minor overhaul)

Bearings/seals and gaskets (major overhaul)

*Gears and shafts sold separately*

SK065

BK065

GK017

# TECHNICAL DATA SHEET



## PRODUCT FEATURES

### 8-BOLT DEEP REACH SIDE MOUNT HIGH TORQUE POWER TAKE-OFF

The 404 series PTO is an extra deep reach PTO designed to fit the left opening of many Mitsubishi transmissions.

#### SUITS:

The following 5 & 6 speed transmissions  
M4S5, M5S5, M5S6, M6S6, M050S6,  
M060S5, M060S6.

- **0.752 - 0.795 REDUCTION RATIO** (depending on transmission)  
For very high torque at the output shaft
- **CONSTANT MESH**  
With heavy duty bearings for longer life
- **WIDE VARIETY OF OUTPUTS**  
To suit many vehicle configurations

## 404 SERIES POWER TAKE-OFF

DEALER: