

TECHNICAL DATA SHEET

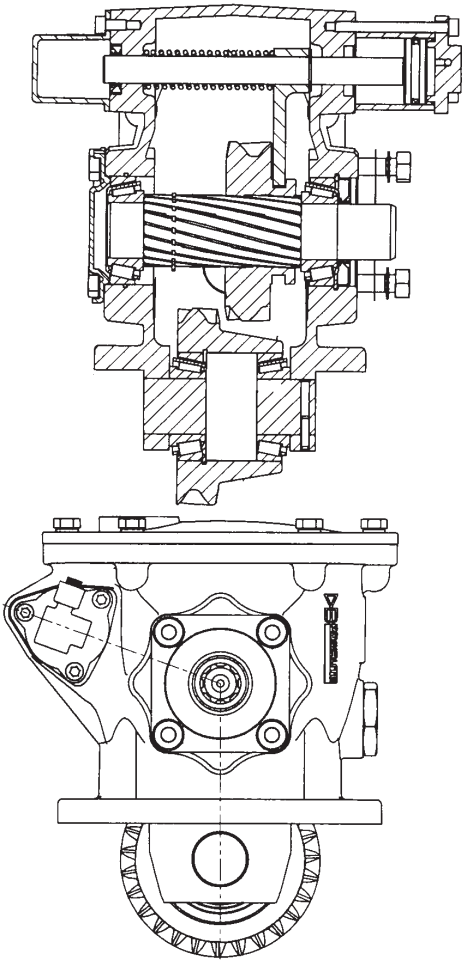

PTO DESIGNATION CODES
403 series PTO

PA 403 SM L21 E 13 *

Identifier
PA = PTO Side mount

PTO Series
403

Gear Type
MK
SM

Build
L = Left side of trans
2 = Selector to bottom
1 = Centre to front - Position of gear in transmission

Engagement Type
A = Air
E = Electric/Air 24V

Output Type
08 = 8T Powauto Hydraulic Spline
09 = 14T 12/24 30° Spline + 35 x 60 Flange
10 = 14T 12/24 30° Spline + 1310 Series Flange
11 = 14T 12/24 30° Spline + 1410 Series Flange
12 = 14T 12/24 30° Spline + DIN 10 Flange
13 = 13T SAE B Hydraulic Spline + Mount
14 = 13T SAE B Hydraulic Spline
23 = 8T ø36 DIN 5462 Female

Manufacturers Code
A = With pressure switch
B, C etc. (internal use only, if required)

For full details refer to owner's manual

Technical Specifications

Rating for intermittent Service	MK	SM
Torque (Nm / lb ft)	396/292	431/317
Power @ 500 rpm (kW / hp)	20.7/27.8	22.4/30.1
Power @ 1000 rpm (kW / hp)	41.4/55.6	44.9/60.2
Output Shaft Rotation	Opposite	Opposite
Approximate Bare Mass (kg / lb)	9.0/20	9.0/20
Mounting Kit	MK1168	MK 1168A

For full details refer to Powauto or consult your applications book.

Spare parts:	Seal Kit:	Seals & gaskets (minor overhaul)	SK047
		Bearing Kit: Bearings/seals and gaskets (major overhaul)	BK047
		Mounting Gasket Kit:	GK011
		<i>Gears and shafts sold separately</i>	

TECHNICAL DATA SHEET

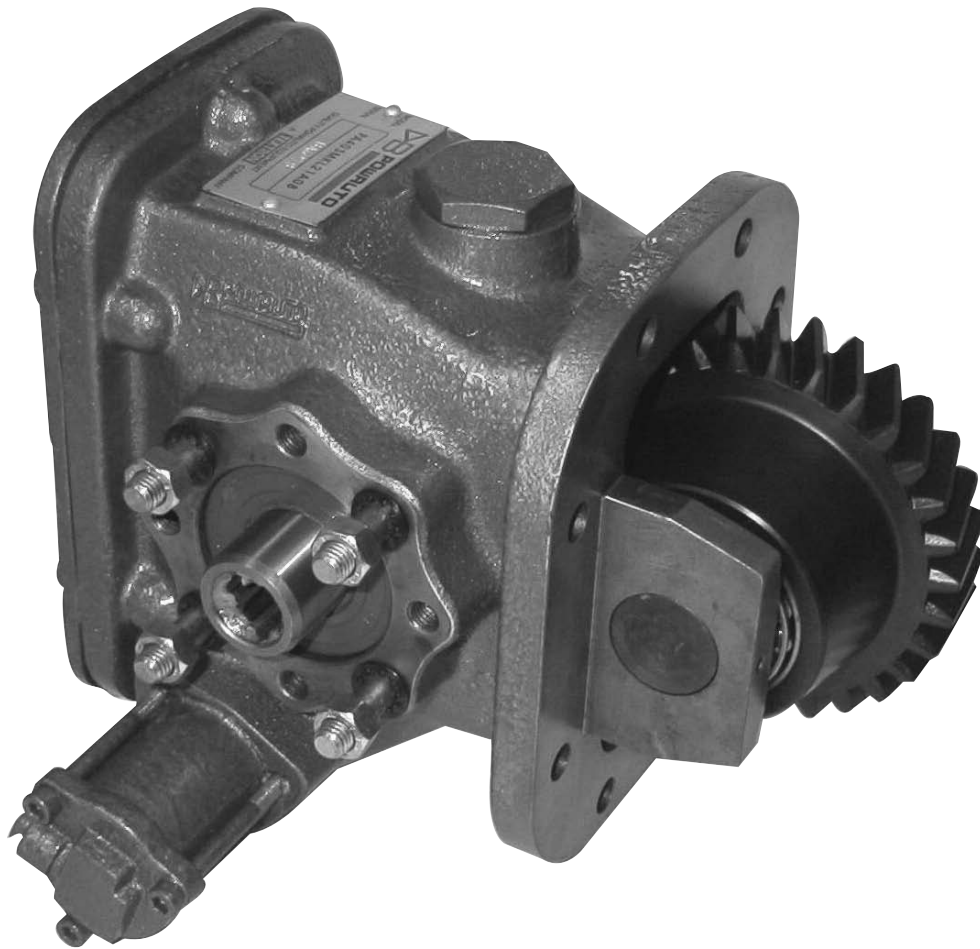

PRODUCT FEATURES

8-BOLT DEEP REACH SIDE MOUNT HIGH TORQUE POWER TAKE-OFF

The 403 series PTO is an extra deep reach PTO designed to fit the left opening of Hino LF & LJ 5 & 6 speed gearboxes.

SUITS:

Certain Hino transmissions.
(Refer to application e-Guide for details)

- **0.86 - 0.93 REDUCTION RATIO** (depending on transmission)
For very high torque at the output shaft
- **CONSTANT MESH**
With heavy duty bearings for longer life
- **WIDE VARIETY OF OUTPUTS**
To suit many vehicle configurations

403 SERIES POWER TAKE-OFF

DEALER: