

# TECHNICAL DATA SHEET



## REAR MOUNTED POWER TAKE-OFF

The 145 series PTO is designed to suit rear of counter shaft apertures.

Suitable for many transmissions, most commonly on European trucks, this PTO comes with a number of configurations.

Refer to your local PTO contact for configurations and specifications on outputs.

### SUITS:

Volvo, Iveco and ZF transmissions.

## 145 SERIES

## POWER TAKE-OFF

### PRODUCT FEATURES

- **BETWEEN 0.6 AND 1.2:1 OUTPUT**  
Dependant on transmission, providing better speeds for hydraulic pumps.
- **SUITABLE FOR REAR OF COUNTER SHAFT OPENINGS**  
When used with the appropriate mounting kit.
- **VARIETY OF OUTPUTS**  
To suit most applications.

DEALER:

# TECHNICAL DATA SHEET

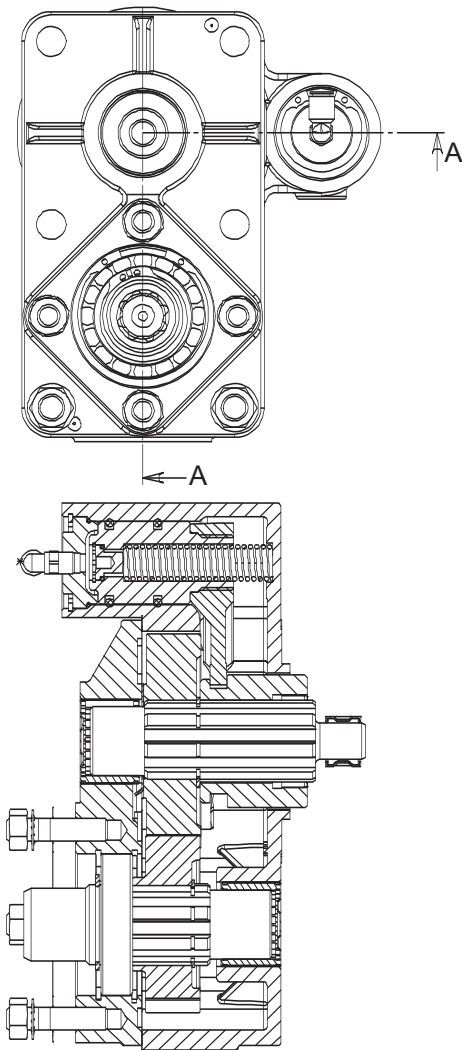

## PTO DESIGNATION CODES 145 series PTO

PB 145 A 08 \*

### Identifier

PB = PTO Rear mount

### PTO series

145

### Engagement Type

A = Air

D = Electric/Air 12V

E = Electric/Air 24V

### Output Type

06 = 8T 36 DIN 5462 Spline + 35 x 60 Flange

07 = 8T 36 DIN 5462 Spline + DIN 00 Flange

08 = 8T Powauto Hydraulic Spline

23 = 8T 36 DIN 5462 Spline - Female

### Manufacturers Code

A = With engaged position switch

B = Sleeve 57155

C = Sleeve 57152

D = Sleeve 57153

E = Sleeve 57152 + engaged position switch + MK1069

G = Sleeve 57152 + engaged position switch

H = Sleeve 57152 + MK1161

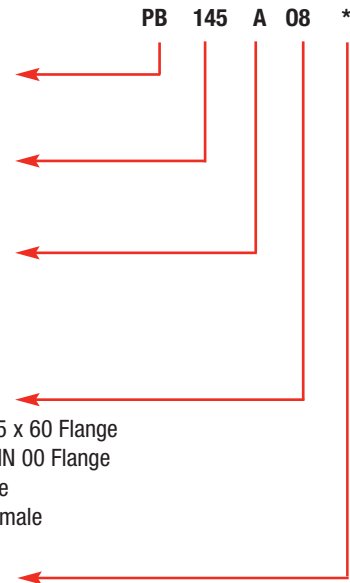

For full details refer to owners' manual.

## Technical Specifications

### Rating for intermittent duty

Torque (Nm /ft lb)	325/240
Power @ 500 rpm output shaft (kW / hp)	17/22.8
Power @ 1000 rpm output shaft (kW / hp)	34/45.6
Output Shaft Rotation	Same
Approximate Bare Mass (kg / lb)	8.5/18.7
Mounting Kit	*

**Refer to application manual for speed/output details and mounting kit details.**

\*Mounting kit varies with transmission - refer to application manual

### Spare parts:

Seal Kit:

Bearing Kit:

Mounting Gasket Kit:

Seals & gaskets (minor overhaul)

Bearings/seals and gaskets (major overhaul)

*Gears and shafts sold separately*

SK074

BK074

GK010